

BST

RESIDENTIAL ENERGY STORAGE BATTERY MODULE



MD48-50-2U



MD48-100-3U

MD 48

- Rack-mounted, 19 inch Modular +
- LiFePO4 Battery, High Safety +
- Flexible Scalability +
- Long Lifespan +
- Compatible with Various Inverters +



Read More

BST POWER (SHENZHEN) LIMITED

+86-0755-84260300

<https://www.bstess.com>

sales@bstbattery.com

701, Building A, No.4 Plant, Baolong Intelligent Manufacturing Park, No.32
Baotong Road, Baolong Community, Baolong Street, Longgang District,
Shenzhen, Guangdong, China

RESIDENTIAL ENERGY STORAGE BATTERY MODULE

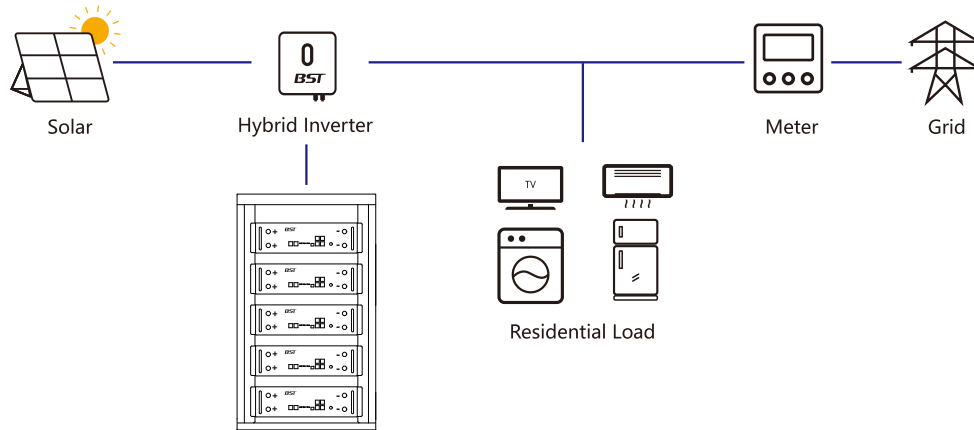

Up to 15 Batteries in Parallel

Model	MD48-50-2U	MD48-100-3U
General		
Nominal Energy	2.4 kWh	5.12 kWh
Usable Energy	2.4 kWh	5.12 kWh
Scalability	Max. 15 in parallel (36kWh)	Max. 15 in parallel (76.8kWh)
Dimension (W x H x D)	440 x 410 x 88.5 mm	440 x 420 x 133 mm
Weight	~24 kg	~44 kg
Design Life	10 Years	10 Years
Electrical		
Nominal Voltage	48 V	51.2 V
Operating Voltage Range	40.5 ~ 53.5 V	43.2 ~ 56.8 V
Charge / Discharge Current	(Recommend)	25A / 25A
	(Maximum)	50A / 50A
Operation		
Charge Temperature	0 ~ 50°C	
Discharge Temperature	-10 ~ 50°C	
Storage Temperature	-20 ~ 45°C	
Humidity	5% ~ 95% RH (No Condensation)	
Altitude	≤4000m	
Ingress Protection	IP20	
Communication Interface	CAN, RS485 (Optional WIFI, BLE)	
Certification	UL1973, UN38.3, EN 61000-6-1, EN 61000-6-3, IEC62619	
Compatible Inverter	BST/Deye/GOODWE/Growatt/Sofar/Solis/Victron/Voltronic	

MD48

2024