

BST

RESIDENTIAL ENERGY STORAGE BATTERY MODULE



MD48-100-3U

MD 48

- Rack-mounted, 19 inch Modular +
- LiFePO4 Battery, High Safety +
- Flexible Scalability +
- Long Lifespan +
- Compatible with Various Inverters +



Read More

BST POWER (SHENZHEN) LIMITED

701, Building A, No.4 Plant, Baolong Intelligent Manufacturing Park, No.32 Baotong Road,
Baolong Community, Baolong Street, Longgang District, Shenzhen, Guangdong, China

<https://www.bstess.com>

Email: sales@bstbattery.com

Tele: 0755-84260300

Fax: 0755-84260306

RESIDENTIAL ENERGY STORAGE BATTERY MODULE

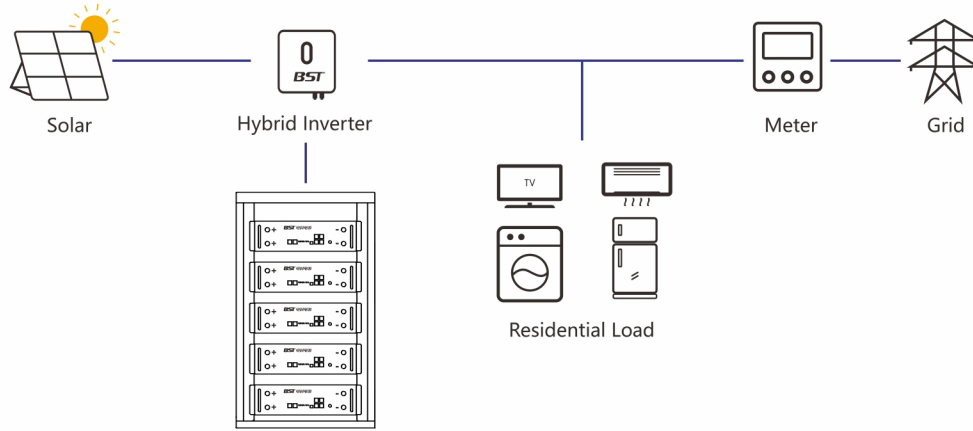

Up to 15 Batteries in Parallel

Model	MD48-100-3U	
General		
Nominal Energy	5.12 kWh	
Usable Energy	5.12 kWh	
Scalability	Max. 15 In Parallel (76.8kWh)	
Dimension (W x H x D)	440 x 420 x 133 mm	
Weight	~44 kg	
Design Life	10 Years	
Electrical		
Nominal Voltage	51.2 V	
Operating Voltage Range	43.2 ~ 56.8 V	
Charge / Discharge Current	(Recommend)	50A / 50A
	(Maximum)	100A / 100A
Operation		
Charge Temperature	0 ~ 50°C	
Discharge Temperature	-10 ~ 50°C	
Storage Temperature	-20 ~ 45°C	
Humidity	5% ~ 95% RH (No Condensation)	
Altitude	≤4000m	
Ingress Protection	IP20	
Communication Interface	CAN, RS485 (Optional WIFI, BLE)	
Certification	UI1973, UN38.3, EN 61000-6-1, EN 61000-6-3, IEC62619	
Compatible Inverter	BST / Deye / Sofar / Solis / Victron / Voltronic	

MD48